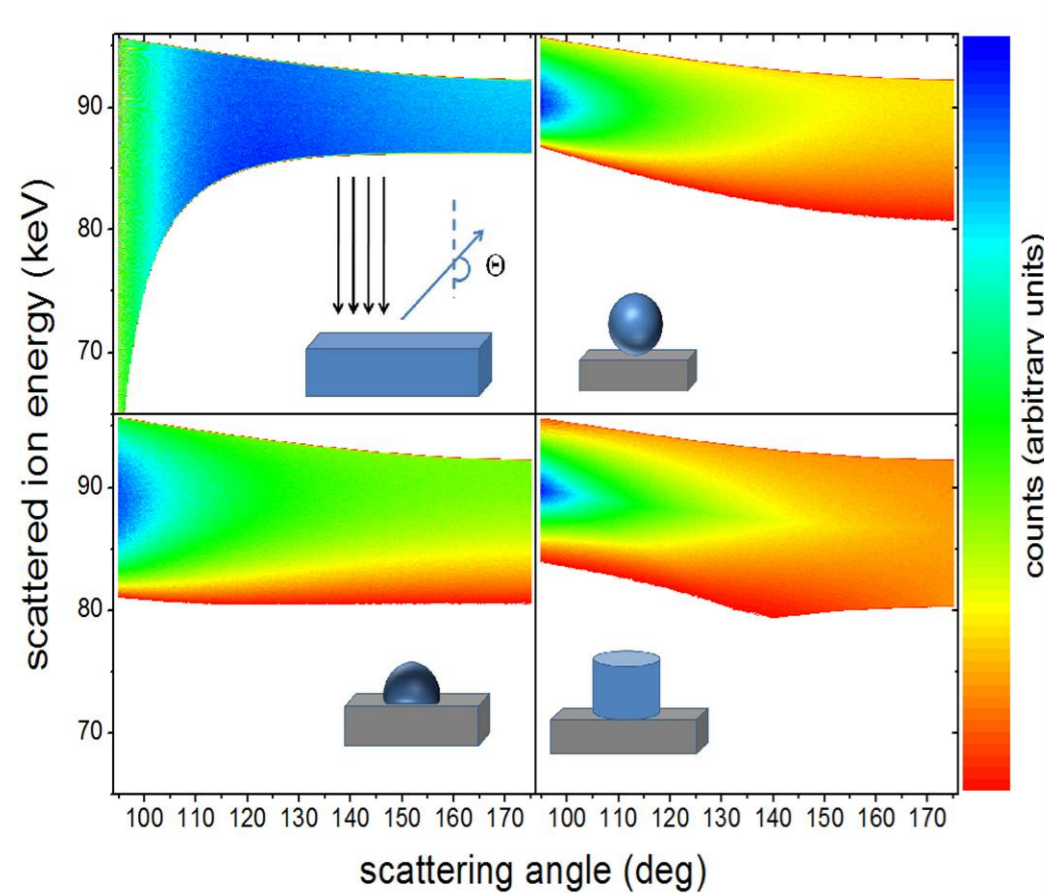


## INTRODUCTION

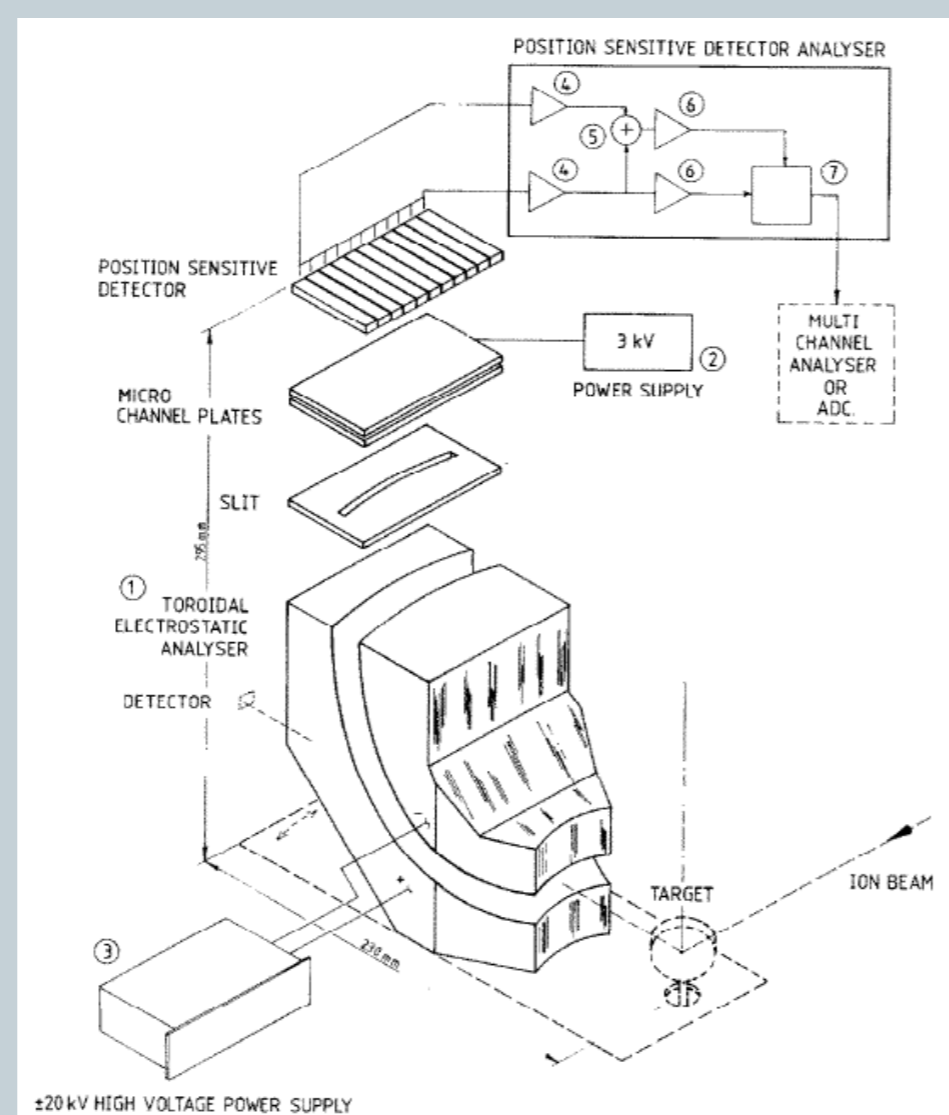
We explored MEIS capabilities to characterize nanoparticles (NPs) by investigating a system of Pb NPs at SiO<sub>2</sub>/Si interface synthesized by ion implantation (7.8 E15 Pb atoms/cm<sup>2</sup>) on a 200nm thick SiO<sub>2</sub>/Si film. The MEIS spectra were analyzed with the Monte Carlo simulation and fitting software developed by our group [1], that considers any shape, size distribution, number density of nanostructures and also the asymmetry of the energy loss-distribution. Undesired effects as multiple scattering and the ion beam's asymmetrical energy-loss line shape, related to the great depth of buried Pb NPs into the SiO<sub>2</sub> film, were minimized through controlled and homogenous chemical etching with fluoridric acid (0,578 molar), partially removing the SiO<sub>2</sub> film (fig. 4). TEM (Transmission Electron Microscopy) images and GISAXS (Grazing-Incidence Small-Angle X-ray Scattering) analysis were used for the MEIS' simulation initial geometrical parameters and mean size of the Pb NPs (fig 3). Comparing the experimental MEIS spectra with the simulated ones for different NPs sizes, it was obtained the mean size of the Pb NPs for two geometrical shape models. It were achieved good fittings with the MEIS spectra and it was observed a good agreement with the data from TEM and GISAXS. The NPs areal number densities were used for each respectively size in order to keep constant the total amount of Pb. The MEIS analysis went beyond determining the NPs structural properties, it was able to unveil an amount of the Pb dissolved into the SiO<sub>2</sub> that was not nucleated, which neither GISAXS or TEM could resolve (fig 5). Crossing information with our previous work [2] we could improve our understanding about the system, when used different synthesizing conditions [3].

## MEIS

MEIS (Medium Energy Ion Spectrometry) is an ion-beam analytical technique with high resolution of energy and angle based on the same physical principles as the RBS (Rutherford Backscattering Spectrometry) which can determine a sample's elemental depth distribution. While the RBS utilizes a solid state detector, in MEIS it is used a toroidal electrostatic analyzer (fig. 2), which has an energy resolution up to 2 orders of magnitude compared to the RBS. Better energy resolution in MEIS allows obtaining depth resolution at subnanometric scale, and propitiates the study of nanostructures' shape, dimension and inner composition (fig. 1). Here, the possibilities and challenges into the characterization of Pb NPs located at the Si/SiO<sub>2</sub> film interface through MEIS and the sample preparation and result analysis processes are presented.

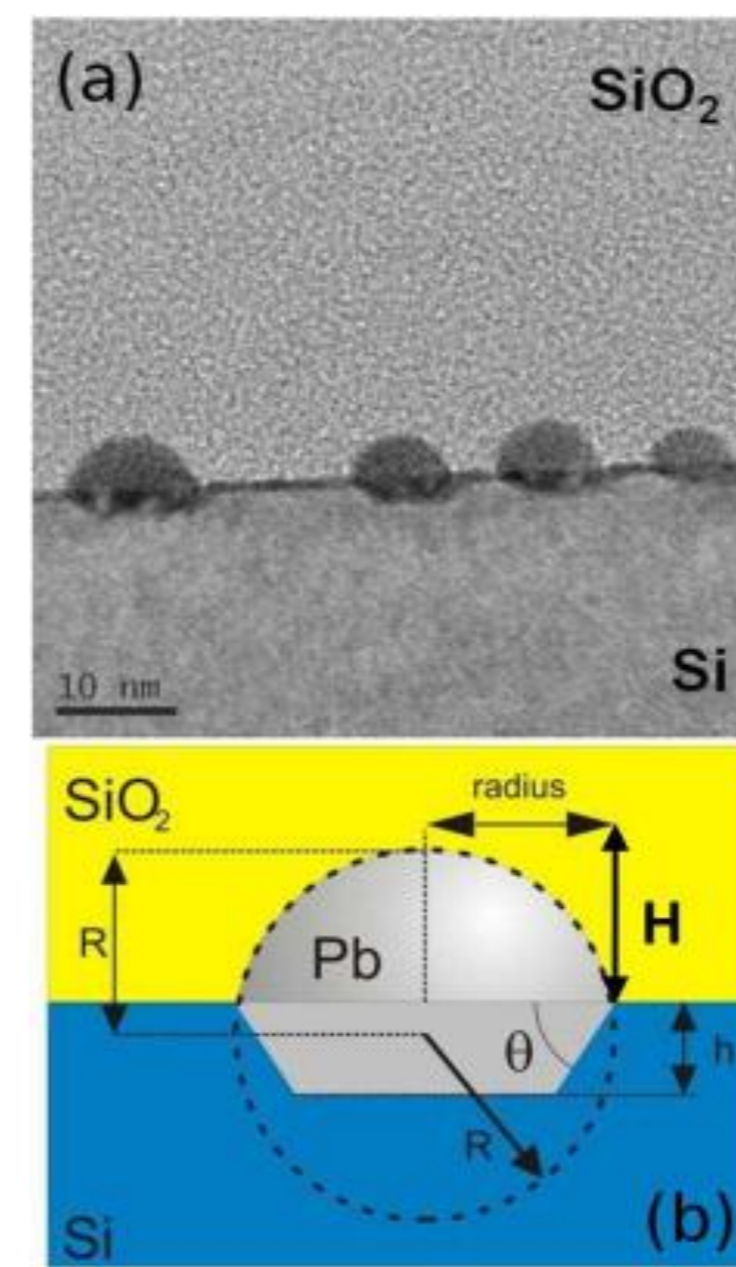


**Fig 1:** MEIS bidimensional (scattering angle vs scattered energy) spectrum examples. The different spectrum's patterns are a result of how different NP shape influences the ions' energy loss.



**Fig 2:** Two toroidal plaques are submitted to a 20Kv tension creating an electrical field between them that deflects the ions based on their energy. These ions are captured by a multichannel plate creating a cascade of electron, which amplifies the signal and is detected by a position sensitive detector.

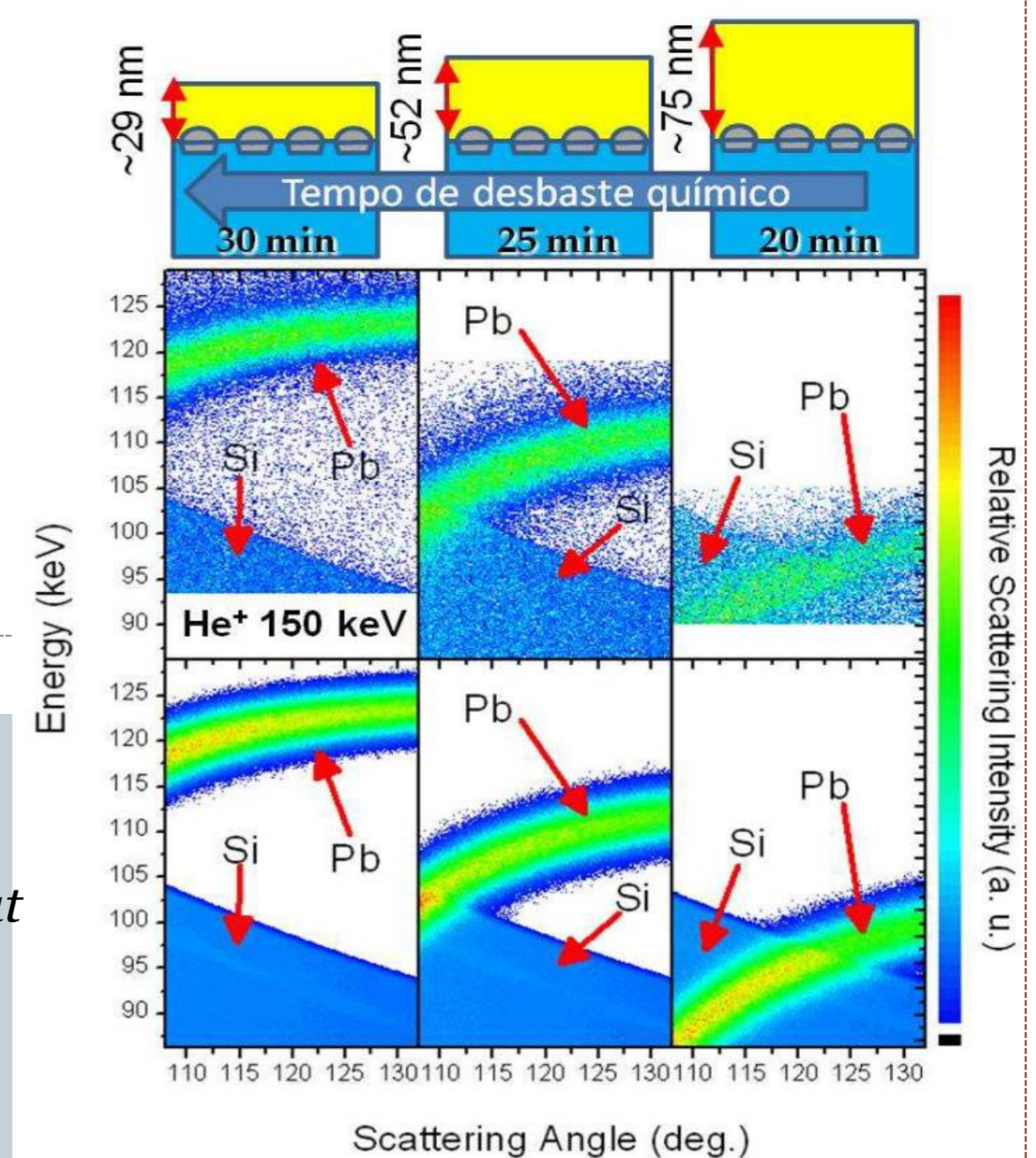
## SAMPLE



**Fig 3:** HRTEM micrograph (top) from the sample presenting a cross section view of the NPs showing that they could be modeled as indicated at the bottom illustration. Although TEM could provide us realistic information for the MEIS simulation, with MEIS and GISAXS the statistic is increased in several orders of magnitudes of NPs.

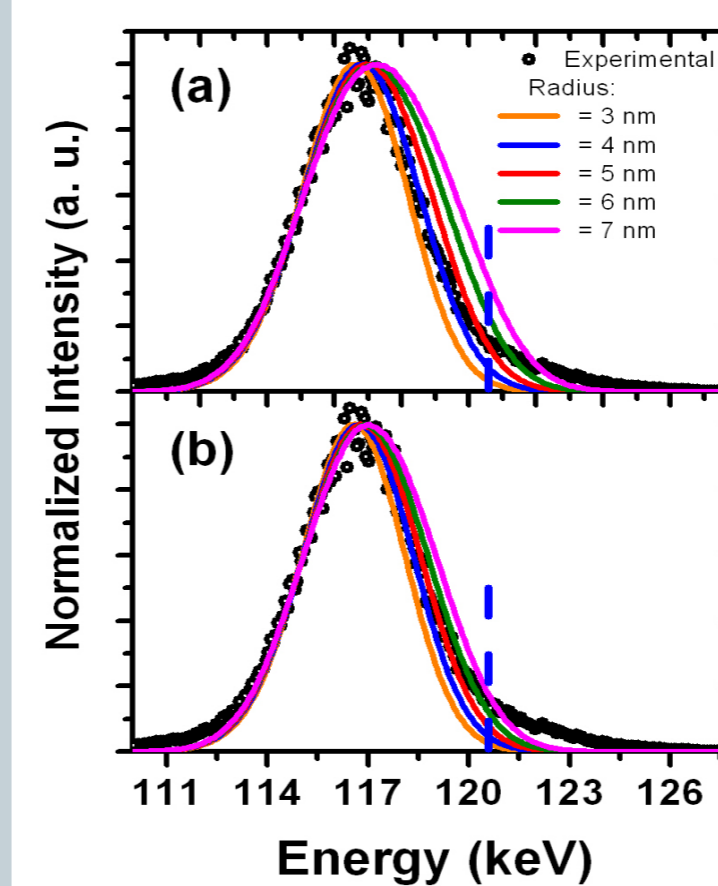
After the Pb<sup>+</sup> implantation, the sample was submitted to a thermal treatments in order to acquire a set of NPs exclusively at the interface [3]:

- 1 - implanting Pb<sup>+</sup> ions accelerated at 300 keV on a 200 nm thick of SiO<sub>2</sub>/Si (001) film.
- 2 - The thermal treatments consists of an ageing (T=200 °C, 100 hours) in open atmosphere, followed by a high temperature annealing (T=1100°C, 1 hour) in high vacuum [3].

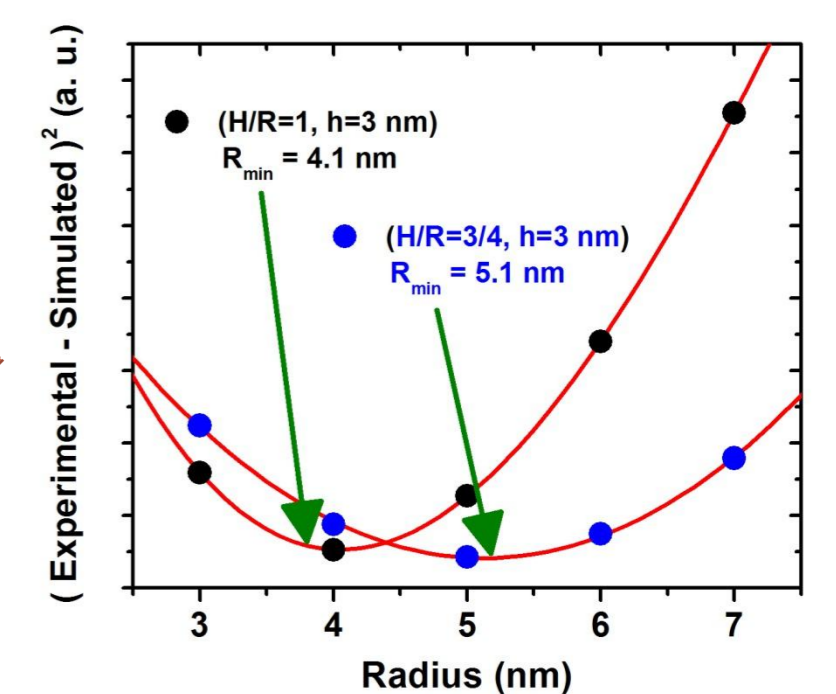


**Fig 4:** 2D Experimental spectrum (top graphics) and simulated ones (bottom) of samples submitted to different chemical etching times, as indicated by the illustration on the top.

## RESULTS AND DISCUSSION



**Fig 5:** The normalized spectrums for each simulated geometry. To the right of the blue dashed line, the experimental data was not related to the Pb NPs, but to 6% of the total amount of Pb atoms which is diluted right above the NPs. This could be seen only through MEIS analysis.



**Fig6:** The results of the two simulated geometries (buried and not buried curvature center). Comparing the experimental MEIS spectra with the simulated ones for different NPs sizes, it was obtained the mean size of the Pb NPs for two geometrical shape models.

## ACKNOWLEDGEMENTS



## REFERENCES

- [1] M. A. Sortica, P. L. Grande, G. Machado, L. Miotti, Journal of Applied Physics 106 (2009) 114320.
- [2] D.F. Sanchez, F.P. Luce, Z. E. Fabrim, M. A. Sortica, P. F. P. Fichtner, P. L. Grande, Surface Science, 605, 654-658, (2011).
- [3] F.P. Luce, F. Kremer, S. Reboh, Z.E. Fabrim, D.F. Sanchez, F.C. Zawislak, P.F.P. Fichtner, J. Appl. Phys. 109, 014320 (2011).